

Note: L1, L2, C8 and C9 should ideally be 5% tolerance for best results. The other components can be 10%. It is better to get C8 and C9 closer to 6n2, e.g. 4.7nF in parallel with 1.5nF.

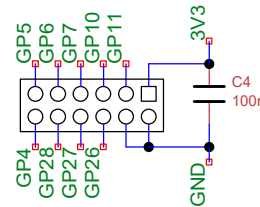
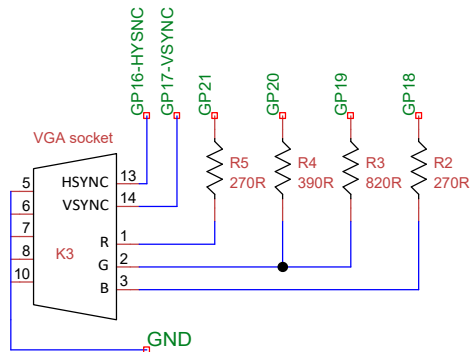

Title		
PicoMite LEO Maxi		
Author		
Mixtel90	MMBasic by Geoff Graham + Peter Mather	
File		
Z:\Documents\PicoMi ... PicoMite LEO Maxi.dsn		
Document		
Revision	Date	Sheets
0.0	July 2022	1 of 1